



LEV: Dust capture at fixed belt sanding machines

Woodworking Sheet No 25

Introduction

This information sheet is one of a series prepared by HSE's Woodworking National Interest Group. General information on the hazards and precautions for wood dust can be found in *Wood dust: Hazards and precautions*.¹ For general guidance on the principles of design of local exhaust ventilation systems see *LEV: General principles of system design*.³ This information sheet gives specific guidance for the design of local exhaust ventilation systems (LEV) fitted to fixed position belt sanding machines, and is relevant to machine designers and users and the designers, installers and users of local exhaust ventilation systems.

Narrow belt sanders

There are three main types of narrow belt sanding machine: large horizontal belt (pad) sanders (see Figure 1); small horizontal belt sanders (linishers) (see Figure 3); and vertical belt sanders (see Figure 4).

The main problems of dust control arise from the movement of the sanding belt which produces air currents which are often strong enough to counteract the exhaust ventilation system. Dust can also be held onto the belt by the build up of static electricity, and anti-static belts can be purchased to overcome this problem.

Large horizontal belt (pad) sanders

Traditionally, these machines have been enclosed at the head pulley only. Any dust which is carried past this enclosure will not be controlled and no control whatsoever is possible when sanding is done on the top run or at the tail pulley. Effective control can be achieved when both the head pulley and the tail pulley are enclosed with an extraction hood. Further improvements

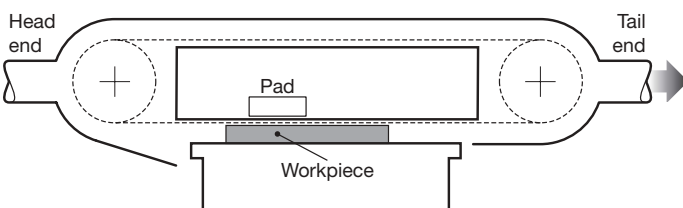

Figure 1 Pad sander with ventilated enclosure of both pulleys and top run

are possible by extending the enclosure across the top of the machine, using a hinged or removable section if sanding is done on the top run (see Figure 1). The extraction will be most effective when the sanding process is carried out close to the inlet of the LEV.

Where control is proving particularly difficult, additional extraction can be fitted in the table of the machine close to the sanding position (see Figure 2). Flanges around the inlet openings will also improve extraction efficiency.²

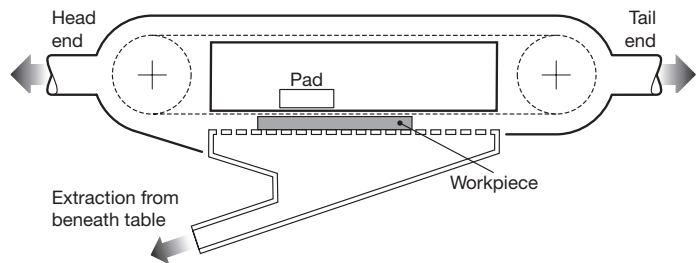

Figure 2 Pad sander with additional extraction through the table

Small horizontal belt sanders (linishers)

Because the workpiece is generally much smaller, dust produced at these sanders is usually easier to control than at large belt sanders. Where enclosure of the sides is impracticable because of the nature of the workpiece, additional captor hoods may be necessary, positioned so as to intercept the dust produced. The addition of flanges around the inlet openings will also improve exhaust efficiency (see Figure 3).

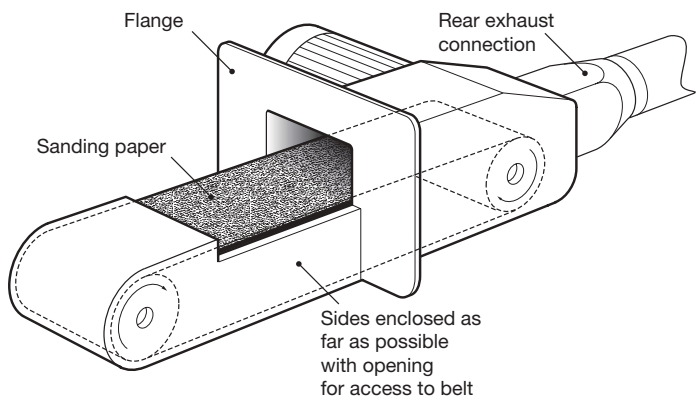

Figure 3 Linisher

Vertical belt sanders

When sanding smaller workpieces, sanding should take place close to the head pulley in order to make best use of the extraction. The arrangement shown in Figure 4 will give effective dust control. In some cases, dust may be carried around with the belt and released as it leaves the enclosure. This can be intercepted by a down-draught grille or secondary hood at the enclosure exit, as shown.

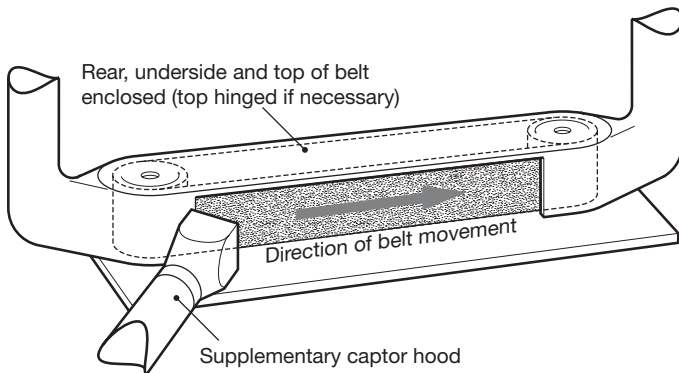

Figure 4 Ventilation system for vertical belt sander

Some sanding may also take place around the tail pulley. Figure 5 shows a way of overcoming the dust control problems when this type of work is carried out.

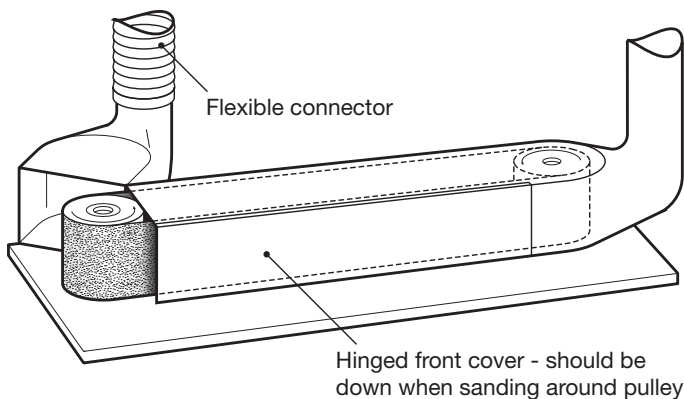

Figure 5 Modified ventilation system for vertical band sander to allow sanding around tail pulley

Reading list and references

- 1 *Wood dust: Hazards and precautions* Woodworking Information Sheet WIS1(rev1) HSE Books 1997
- 2 *An introduction to local exhaust ventilation HSG37* HSE Books 1993 ISBN 0 7176 1001 2
- 3 *LEV: General principles of system design* Woodworking Information Sheet WIS23 HSE Books 1992
- 4 *Control of substances hazardous to health. The Control of Substances Hazardous to Health Regulations 2002. Approved Code of Practice and guidance L5 (Fourth edition)* HSE Books 2002 ISBN 0 7176 2534 6
- 5 *Assessment and control of wood dust: Use of a dust lamp* Woodworking Information Sheet WIS12 HSE Books 1991

Further information

HSE priced and free publications are available by mail order from HSE Books, PO Box 1999, Sudbury, Suffolk CO10 2WA Tel: 01787 881165 Fax: 01787 313995 Website: www.hsebooks.co.uk (HSE priced publications are also available from bookshops and free leaflets can be downloaded from HSE's website: www.hse.gov.uk.)

For information about health and safety ring HSE's Infoline Tel: 08701 545500 Fax: 02920 859260 e-mail: hseinformationservices@natbrit.com or write to HSE Information Services, Caerphilly Business Park, Caerphilly CF83 3GG.

This leaflet contains notes on good practice which are not compulsory but which you may find helpful in considering what you need to do.

© Crown copyright This publication may be freely reproduced, except for advertising, endorsement or commercial purposes. First published 10/92. Please acknowledge the source as HSE.